

JADS™ SERIES

All Electric Servo Drive Injection Molding Machine

JSW THE JAPAN STEEL WORKS, LTD.

<https://www.jsw.co.jp/en/>

Division Gate City Ohsaki-West Tower, 11-1, Osaki 1-chome, Shinagawa-ku, Tokyo 141-0032, Japan
 Head Quarter: Phone: +81-3-5745-2081 URL https://www.jsw.co.jp/en/products/injection_molding/

Japan Steel Works America, Inc.

Head Office: 1251 Avenue of the Americas, Suite 2390, New York, NY 10020, U.S.A.
 Phone: +1-212-490-2630

New Jersey Technical & Distribution Center:
 1881 Route 46, Ledgewood, NJ 07852, U.S.A.
 Phone: +1-732-285-1952

California Office: 1890 S Carlos Avenue, Building 15, Unit 6, Ontario, CA 91761, U.S.A.
 Phone: +1-909-740-3808

Georgia Office: 1395 S. Marietta Pkwy, Bldg. 200, Suite 201, Marietta, GA 30067, U.S.A.
 Phone: +1-770-575-0383

Illinois Office: 201 Hansen Court, Suite 121, Wood Dale, IL 60191, U.S.A.
 Phone: +1-630-716-3400

Michigan Office: 24387 Halsted Road Unit B, Farmington Hills, MI 48335, U.S.A.
 Phone: +1-248-536-0288

The Japan Steel Works (Singapore) Pte. Ltd.

17 Gul Lane 629413, Singapore
 Phone: +65-6861-4511

PT. JSW Plastics Machinery Indonesia

Gajah Building Unit AP, Jl. Dr. Saharjo Raya No.111 Tebet
 Jakarta Selatan 12810, Indonesia
 Phone: +62-21-8370-2536

JSW Plastics Machinery (Philippines) Inc.

Unit 2205, 22nd Floor, Asian Star Building, Asean Drive,
 Filinvest Corporate City, Alabang, Muntinlupa City, 1781, Philippines
 Phone: +63-2-8478-2533

JSW Plastics Machinery (M) SDN. BHD.

D12-3A Block D12, Pusat Perdagangan Dana 1, Jalan PJU 1A/46, 47301
 Petaling Jaya, Selangor, Malaysia
 Phone: +60-3-7842-6076

The Japan Steel Works (Thailand) Co., Ltd.

78/6 JST Building 4th Floor, Moo 7 King Kaew Road, Rachatewa, Bangplee,
 Samutprakarn 10540, Thailand
 Phone: +66-2-738-5272

JSW Plastics Machinery Vietnam Ltd.

Hanoi Head Office: Room103, Techno-Center Thang Long Industrial Park, Kim Chung Commune,
 Dong Anh District, Hanoi, Vietnam
 Phone: +84-24-3951-6383

Ho Chi Minh Office: Ground Floor, DC Tower, 111D Ly Chinh Thang, Ward 7, District 3, HCC, Vietnam
 Phone: +84-28-3526-1295

JSW Plastics Machinery (H.K.) Co., Ltd.

Room 907, Corporation Park, 11 On Lai Street, Shatin N.T., Hong Kong
 Phone: +852-2648-0720

JSW Plastics Machinery (Shenzhen) Co., Ltd.

No.101A, 1st Floor Building 6, Nangang 2nd Industrial Park, Songbai Road No.1026, Yangguang Community,
 Xili Street, Nanshan District, Shenzhen, Guangdong Province, 518055 P.R.China
 Phone: +86-755-8602-0930

JSW Machinery Trading (Shanghai) Co., Ltd.

301, Metro Plaza, No.555 Loushanguan Road, Changning District,
 Shanghai, 200051, P.R.China
 Phone: +86-21-5206-7031

JSW Plastics Machinery (Taiwan) Corp.

Head Office: 1F, No.21, Dahu 1st Road, Gueishan Dist., Taoyuan City, 33373 Taiwan, R.O.C.
 Phone: +886-3-396-2102

Tainan Office: No.69, Dongciao 6th St, Yongkang Dist., Tainan City, 710038, Taiwan (R.O.C.)
 Phone: +886-6-311-4192

Japan Steel Works India Private Limited

611, Time Tower, MG Road, Sector 28, Gurgaon, Haryana, 122001, India
 Phone: +91-124-469-4444

JSW Plastics Machinery Mexico S. de R.L. de C.V.

Avenida Mineral de Valenciana 202 A-1, Parque Industrial Santa Fe,
 Silao, De La Victoria, Guanajuato C.P: 36275, Mexico
 Phone: +52-472-748-9412

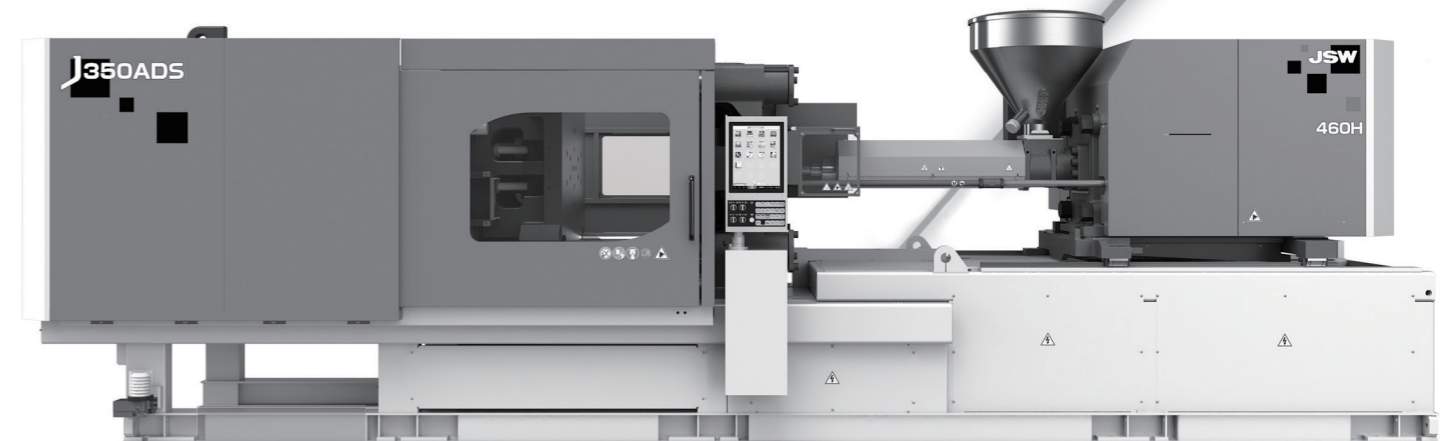

Model
J220ADS | J280ADS | J350ADS | J450ADS

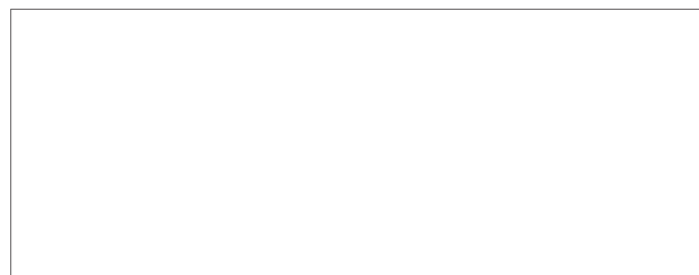

2024.5

JSW



JQA-QMA13993
 JQA-EM6416

Performance Table

Equipment Dimensions and Mold Related Dimensions

Unit	Model	J220ADS										
		300H			460H			890H				
Injection Unit	Screw Diameter	mm	40	46	51	46	53	58	58	66	72	
	Screw Stroke	mm	180									
	Theoretical Injection Capacity	cm ³	226	299	368	349	463	555	687	890	1059	
	Injection Capacity (GP-PS)	g	206	273	335	318	421	505	625	810	965	
	Standard	Injection Pressure (Max.)	MPa(kgf/cm ²)	250{2550}	189{1920}	154{1570}	234{2380}	177{1800}	147{1490}	229{2330}	177{1800}	149{1510}
		Holding Pressure (Max.)	MPa(kgf/cm ²)	227{2310}	172{1750}	140{1420}	213{2170}	161{1640}	134{1360}	208{2120}	161{1640}	135{1370}
		Injection Speed	mm/s	240			160			160		
		Injection Rate	cm ³ /s	302	399	490	266	353	423	423	547	651
		Plasticizing Rate (GP-PS)	kg/h	130	184	232	115	163	197	197	282	336
		Screw Speed	min ⁻¹	400			250			250		
	High Speed (Option)	Injection Pressure (Max.)	MPa(kgf/cm ²)	250{2550}	189{1920}	154{1570}	234{2380}	177{1800}	147{1490}	229{2330}	177{1800}	149{1510}
		Holding Pressure (Max.)	MPa(kgf/cm ²)	227{2310}	172{1750}	140{1420}	213{2170}	161{1640}	134{1360}	208{2120}	161{1640}	135{1370}
		Injection Speed	mm/s	330			300			270		
		Injection Rate	cm ³ /s	415	548	674	499	662	793	713	924	1099
		Plasticizing Rate (GP-PS)	kg/h	130	184	232	161	228	275	197	282	336
Screw Speed		min ⁻¹	400			350			250			
Clamping Unit	Nozzle Touch Force	kN (tf)	39.3{4.0} Center Nozzle Touch									
	Nozzle Stroke from Platen	mm	50									
	Type of Nozzle		Open Nozzle (Tip Type)									
	Barrel Temperature Control		Barrel4, Nozzle1			Barrel5, Nozzle1						
	Heater Wattage	kW	12.0			12.4			18.7			
	Mechanism		Double Toggle									
	Clamping Force	kN (tf)	2160{220}									
	Daylight Opening (Max.)	mm	1230									
	Opening Stroke (Max.)	mm	550									
	Mold Height	mm	230~680									
	Distance Between Tie-bars (H×V)	mm	650×590									
	Platen Size (H×V)	mm	930×870									
	Locating Ring Diameter	mm	φ120H7 (Depth15)									
	Ejector Point		13 Points									
	Ejector Force	kN (tf)	44.2{4.5}									
Ejector Stroke	mm	150										
General	Machine Weight	t	10.5			11.1			11.6			
	Machine Dimensions (L×W×H)	m	6.36×1.68×2.00			6.36×1.68×2.03			7.02×1.68×2.06			

- Remarks:
- Maximum injection pressure and maximum holding pressure may be restricted due to molding condition.
 - The theoretical injection capacity is (cross sectional area of barrel) × (stroke of screw).
 - The injection capacity is applicable for GP-PS and variable according to the grade of resin, molding conditions and mold.
 - The plasticizing rate is applicable for GP-PS.
 - PC, HPVC, other engineering plastic, etc., low temperature setting and high speed molding may require a high torque depending on the grade or molding conditions. Please contact us if you plan.

- Note:
- Due to continual improvements, specifications are subject to change without notice.
 - Actual figures of the specification will vary depending on final machine configuration. Please contact us if you require more specific data.
 - Performance specifications are based on theoretical data.
 - High speed injection is optional.
 - 1MPa=10.2 kgf/cm², 1kN=0.102tf

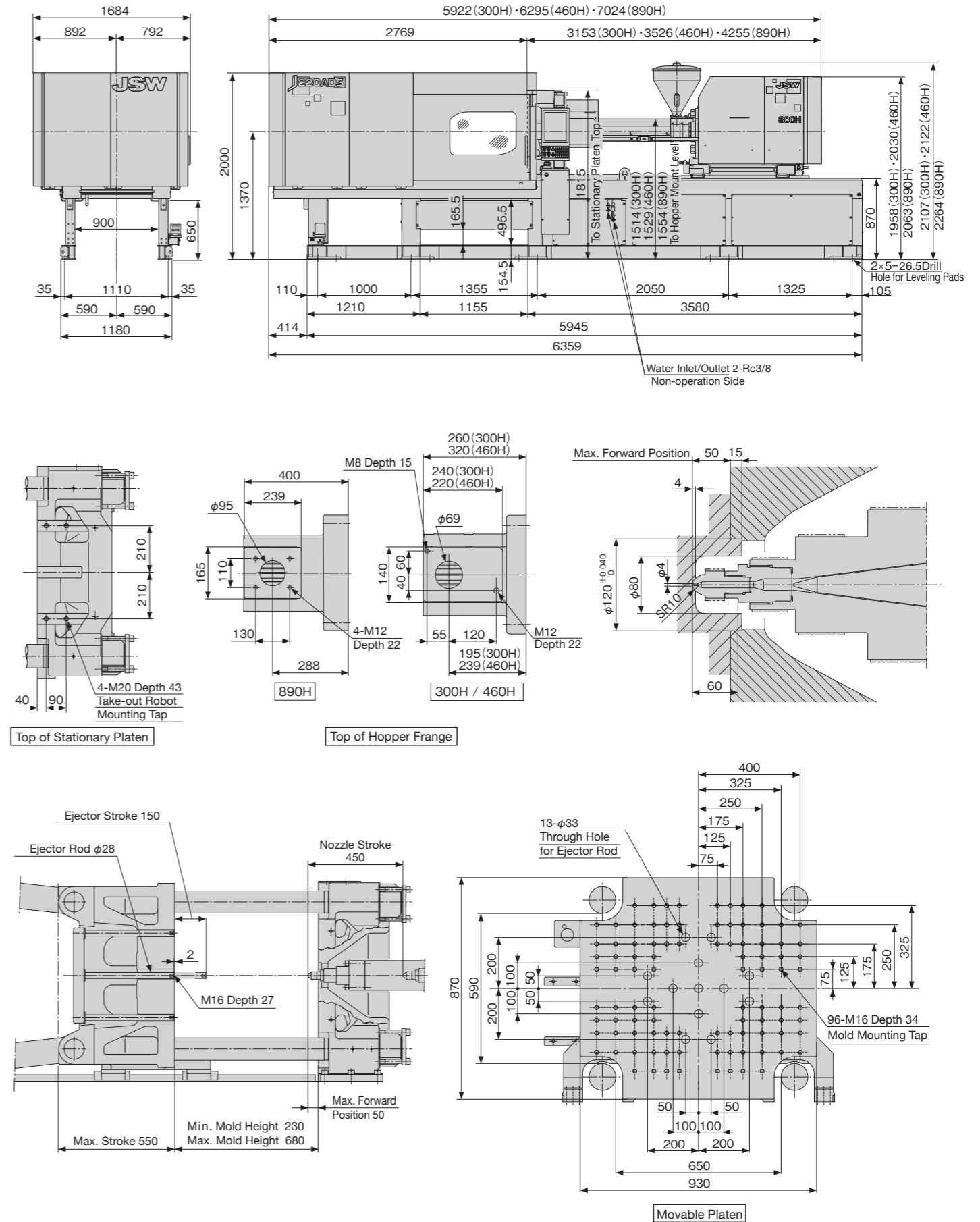

Performance Table

Equipment Dimensions and Mold Related Dimensions

Unit	Model	J350ADS									
		460H			890H			1400H			
Screw Diameter	mm	46	53	58	58	66	72	66	76	84	
Screw Stroke	mm	210									
Theoretical Injection Capacity	cm ³	349	463	555	687	890	1059	1026	1361	1663	
Injection Capacity (GP-PS)	g	318	421	505	625	810	965	934	1238	1513	
Injection Unit	Standard	Injection Pressure (Max.) MPa(kgf/cm ²)	234 [2380]	177 [1800]	147 [1490]	229 [2330]	177 [1800]	149 [1510]	241 [2450]	182 [1850]	149 [1510]
		Holding Pressure (Max.) MPa(kgf/cm ²)	213 [2170]	161 [1640]	134 [1360]	208 [2120]	161 [1640]	135 [1370]	216 [2200]	163 [1660]	134 [1360]
		Injection Speed	160			160			160		
		Injection Rate	266	353	423	423	547	651	547	726	887
		Plasticizing Rate (GP-PS)	115	163	197	197	282	336	237	338	418
	Screw Speed	250			250			210			
	High Speed (Option)	Injection Pressure (Max.) MPa(kgf/cm ²)	234 [2380]	177 [1800]	147 [1490]	229 [2330]	177 [1800]	149 [1510]	241 [2450]	182 [1850]	149 [1510]
		Holding Pressure (Max.) MPa(kgf/cm ²)	213 [2170]	161 [1640]	134 [1360]	208 [2120]	161 [1640]	135 [1370]	216 [2200]	163 [1660]	134 [1360]
		Injection Speed	300			270			300		
		Injection Rate	499	662	793	713	924	1099	1026	1361	1663
Plasticizing Rate (GP-PS)		161	228	275	197	282	336	237	338	418	
Screw Speed	350			250			210				
Nozzle Touch Force	kN [tf]	39.3 [4.0] Center Nozzle Touch									
Nozzle Stroke from Platen	mm	50									
Type of Nozzle		Open Nozzle (Tip Type)									
Barrel Temperature Control		Barrel 5, Nozzle 1									
Heater Wattage	kW	12.4			18.7			26.8			
Mechanism		Double Toggle									
Clamping Force	kN [tf]	3440 [350]									
Daylight Opening (Max.)	mm	1470									
Opening Stroke (Max.)	mm	700									
Mold Height	mm	300~770									
Distance Between Tie-bars (HXV)	mm	810×730									
Platen Size (HXV)	mm	1165×1085									
Locating Ring Diameter	mm	φ150H7 (Depth20)									
Ejector Point		17 Points									
Ejector Force	kN [tf]	59.0 [6.0]									
Ejector Stroke	mm	150									
General	Machine Weight	16.1			17.0			18.5			
	Machine Dimensions (L×W×H) m	6.99×1.95×2.09			7.61×1.96×2.09			7.80×1.95×2.15			

Remarks:

- Maximum injection pressure and maximum holding pressure may be restricted due to molding condition.
- The theoretical injection capacity is (cross sectional area of barrel) × (stroke of screw).
- The injection capacity is applicable for GP-PS and variable according to the grade of resin, molding conditions and mold.
- The plasticizing rate is applicable for GP-PS.
- PC, HPVC, other engineering plastic, etc., low temperature setting and high speed molding may require a high torque depending on the grade or molding conditions. Please contact us if you plan.

Note:

- Due to continual improvements, specifications are subject to change without notice.
- Actual figures of the specification will vary depending on final machine configuration. Please contact us if you require more specific data.
- Performance specifications are based on theoretical data.
- High speed injection is optional.
- 1MPa=10.2 kgf/cm², 1kN=0.102tf

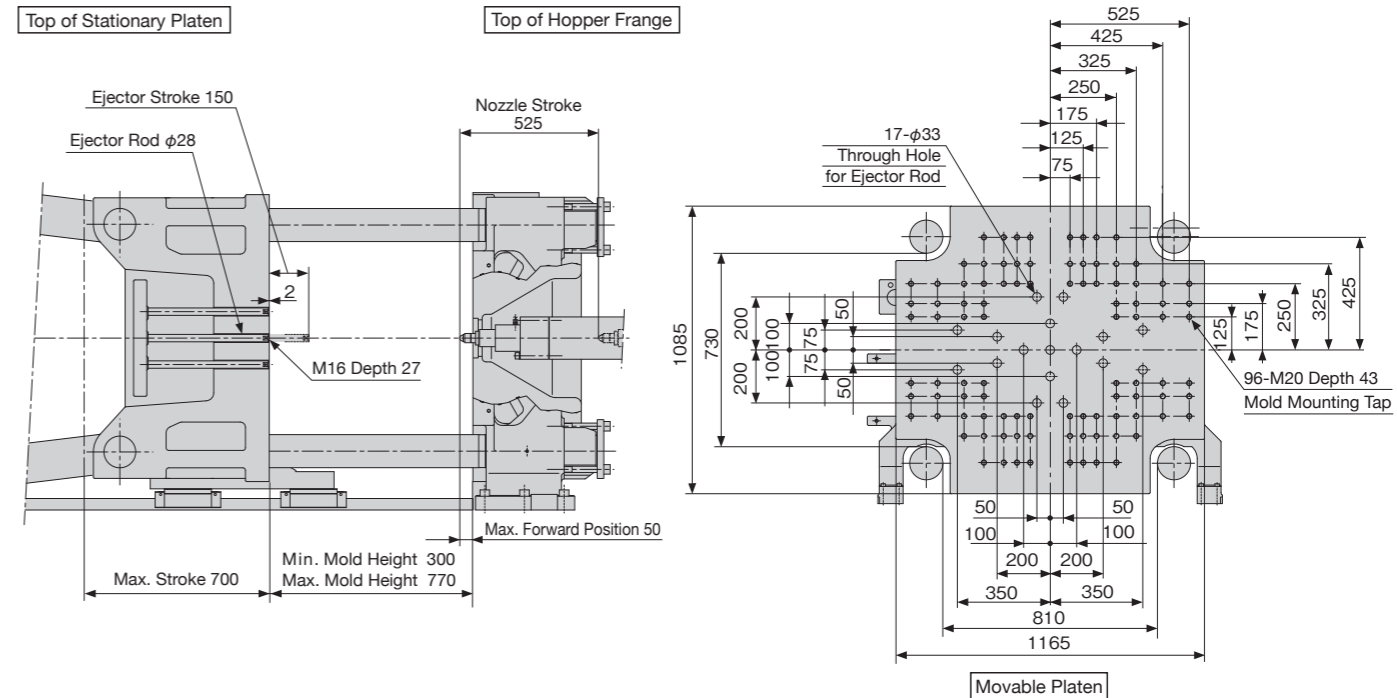
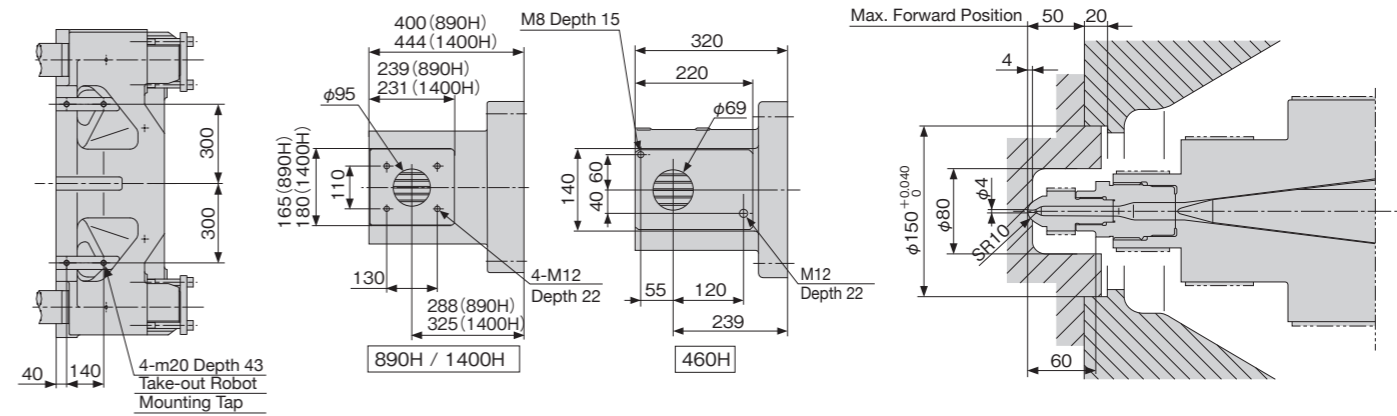
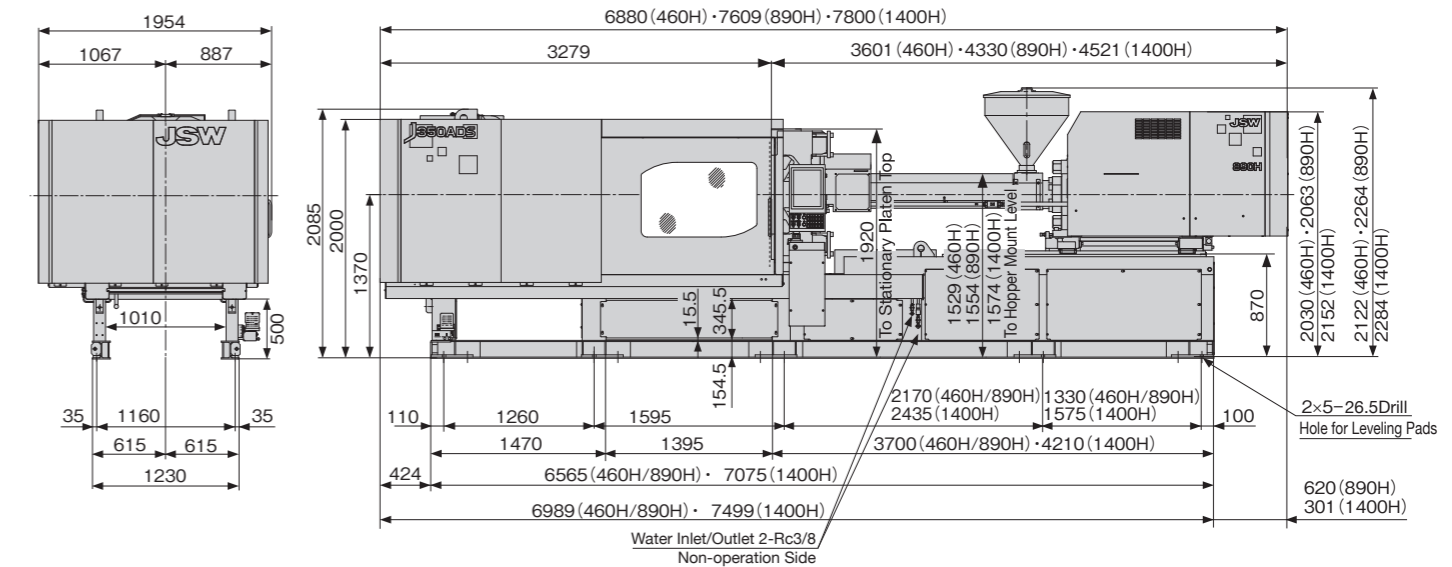

Performance Table

Equipment Dimensions and Mold Related Dimensions

Unit	Model	J450ADS										
		890H			1400H			2300H				
Injection Unit	Screw Diameter	mm	58	66	72	66	76	84	76	84	92	
	Screw Stroke	mm	260									
	Theoretical Injection Capacity	cm ³	687	890	1059	1026	1361	1663	1905	2328	2792	
	Injection Capacity (GP-PS)	g	625	810	965	934	1238	1513	1734	2118	2541	
	Standard	Injection Pressure (Max.)	MPa(kgf/cm ²)	229 {2330}	177 {1800}	149 {1510}	241 {2450}	182 {1850}	149 {1510}	195 {1980}	190 {1930}	158 {1610}
		Holding Pressure (Max.)	MPa(kgf/cm ²)	208 {2120}	161 {1640}	135 {1370}	216 {2200}	163 {1660}	134 {1360}	176 {1790}	171 {1740}	142 {1440}
		Injection Speed	mm/s	160			160			160		
		Injection Rate	cm ³ /s	423	547	651	547	726	887	726	887	1064
		Plasticizing Rate (GP-PS)	kg/h	197	282	336	237	338	418	390	450	470
		Screw Speed	min ⁻¹	250			210			210		
	High speed (Option)	Injection Pressure (Max.)	MPa(kgf/cm ²)	229 {2330}	177 {1800}	149 {1510}	241 {2450}	182 {1850}	149 {1510}	195 {1980}	190 {1930}	158 {1610}
		Holding Pressure (Max.)	MPa(kgf/cm ²)	208 {2120}	161 {1640}	135 {1370}	216 {2200}	163 {1660}	134 {1360}	176 {1790}	171 {1740}	142 {1440}
		Injection Speed	mm/s	270			300			240		
		Injection Rate	cm ³ /s	713	924	1099	1026	1361	1663	1089	1330	1595
Plasticizing Rate (GP-PS)		kg/h	197	282	336	237	338	418	390	450	470	
Screw Speed		min ⁻¹	250			210			210			
Clamping Unit	Nozzle Touch Force	kN {tf}	39.3 {4.0} Center Nozzle Touch						59.0 {6.0}			
	Nozzle Stroke from Platen	mm	50									
	Type of Nozzle		Open Nozzle (Tip Type)						Open Nozzle			
	Barrel Temperature Control		Barrel5, Nozzle1									
	Heater Wattage	kW	18.7			26.8			34.1			
	Mechanism		Double Toggle									
	Clamping Force	kN {tf}	4420 {450}									
	Daylight Opening (Max.)	mm	1700									
	Opening Stroke (Max.)	mm	800									
	Mold Height	mm	350~900									
	Distance Between Tie-bars (HXV)	mm	900×810									
	Platen Size (HXV)	mm	1300×1210									
	Locating Ring Dia	mm	φ150H7 (Depth20)									
Ejector Point		17 Points										
Ejector Force	kN {tf}	99.0 {10.0}										
Ejector Stroke	mm	180										
General	Machine Weight	t	21.0			22.3			24.0			
	Machine Dimensions (L×W×H)	m	8.05×2.10×2.20			8.25×2.10×2.21			8.92×2.11×2.39			

Remarks:
 1. Maximum injection pressure and maximum holding pressure may be restricted due to molding condition.
 2. The theoretical injection capacity is (cross sectional area of barrel) × (stroke of screw).
 3. The injection capacity is applicable for GP-PS and variable according to the grade of resin, molding conditions and mold.
 4. The plasticizing rate is applicable for GP-PS.
 5. PC, HPVC, other engineering plastic, etc., low temperature setting and high speed molding may require a high torque depending on the grade or molding conditions. Please contact us if you plan.

Note:
 1. Due to continual improvements, specifications are subject to change without notice.
 2. Actual figures of the specification will vary depending on final machine configuration. Please contact us if you require more specific data.
 3. Performance specifications are based on theoretical data.
 4. High speed injection is optional.
 5. 1MPa=10.2 kgf/cm², 1kN=0.102tf

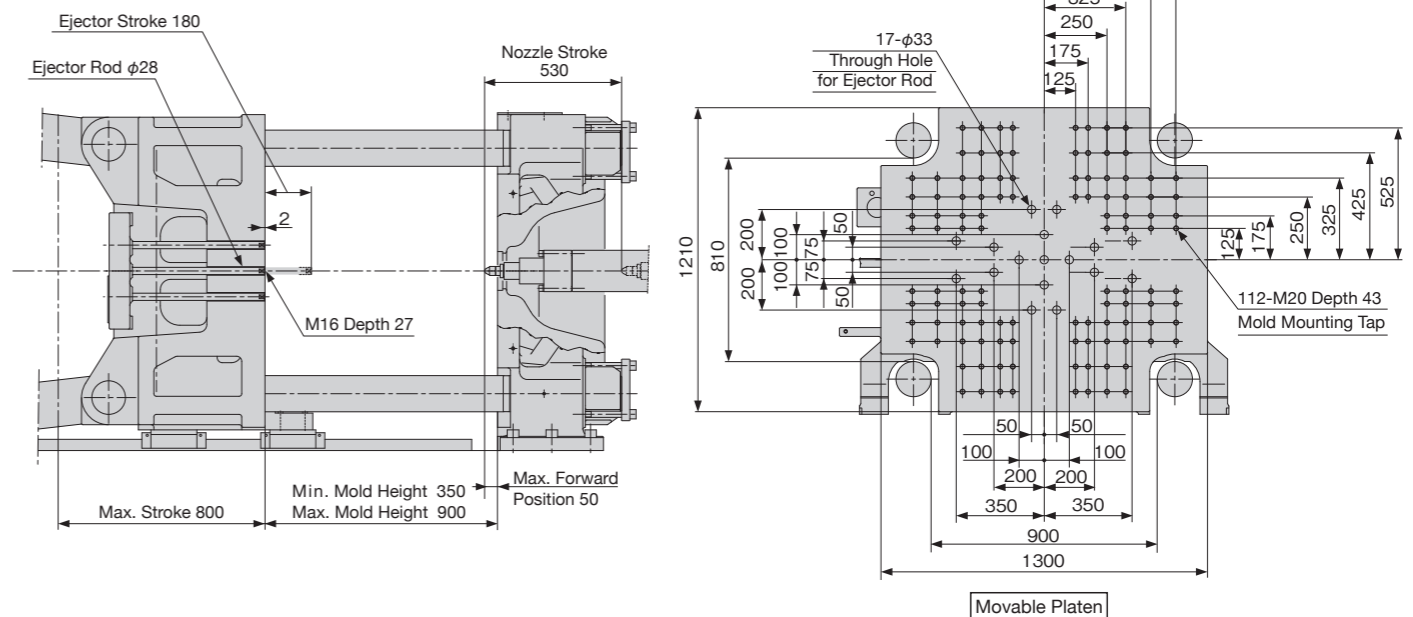
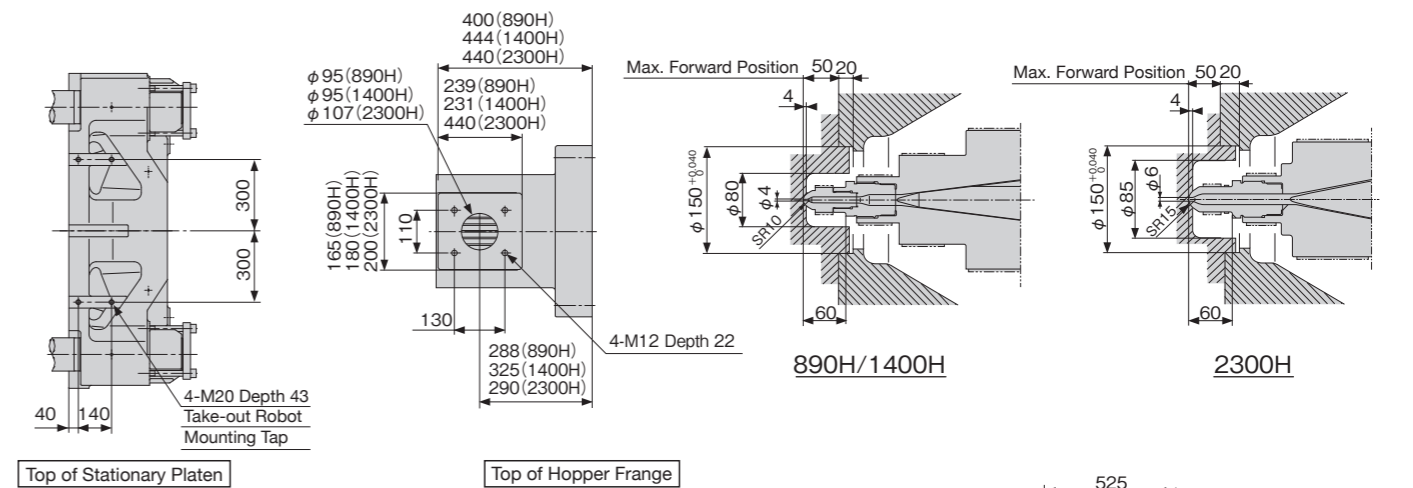
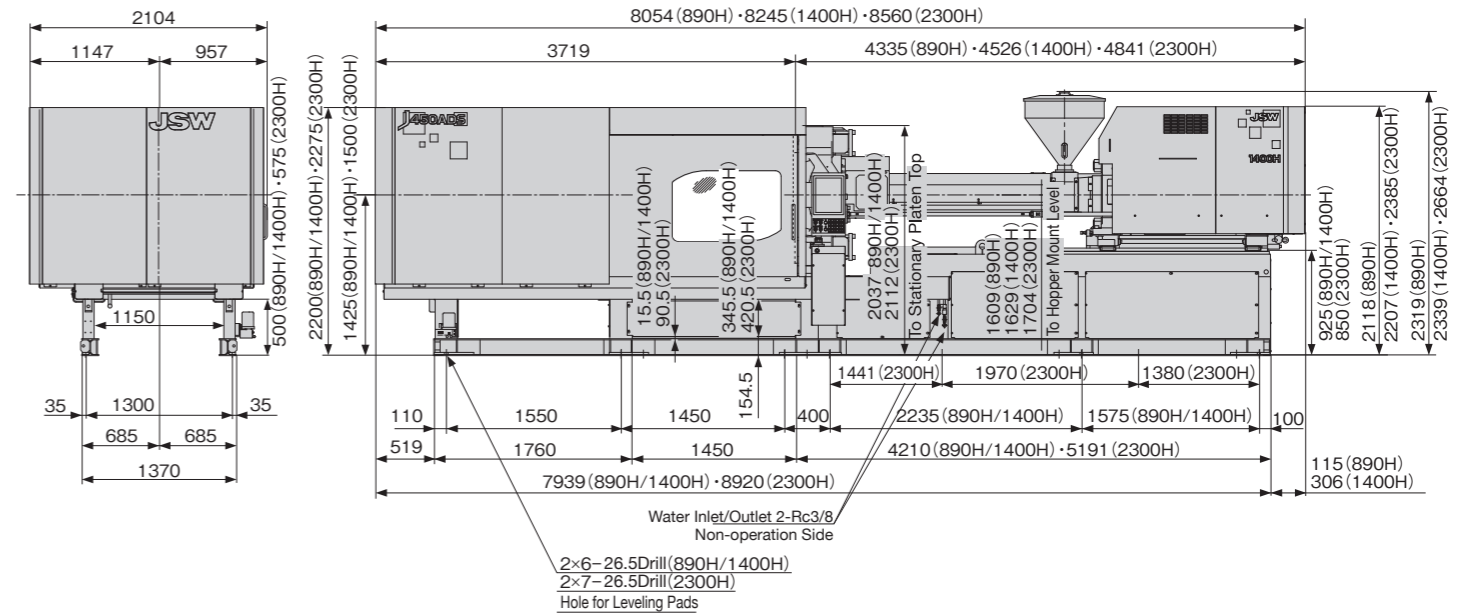

Standard Equipment List

Item		
Injection unit	Open Nozzle (Tip type)/(Injection Units up to 1400H) (Note 1)	
	N2000F Barrel	
	Chrome-plated Screw (Note 2)	
	Screw Pull-back	
	Injection Unit Swiveling Device (with Limit Switch)	
	Screw Cold Start Prevention	
	Molding/Purging/Pause Temperature Select	
	Auto Purging Circuit	
	Nozzle Retract Select	
	Injection/Metering Programmed Control	Injection/Holding Pressure:1 to 6 Steps (Variable) Metering/Back Pressure:1 to 3 Steps (Variable)
	Holding Pressure Transfer Select	
	Holding Pressure Control Select	
	Pull-back Select	
	Barrel Temperature Control (PID/SSR)	
	Synchronous Temperature Rise Control	
	Hopper Flange Temperature Control	
	Soft Pack Servo Control	
	HAVC (High Accuracy Volume Control)	
	IWCS (Injection Weight and Cushion Stability) Control	
	Reverse seal Control	
Auto Grease Lubrication		
Clamping unit	High-performance Platen Support	
	Low Vibration Mold Open/Close	
	Wide Platen	
	Flat Press Platen Mechanism (Stationary side/Movable side)	
	Mold Open/Close and Ejection Programmed Control	Mold Open/Close : 4 Steps (Fixed) Ejection : 1 to 3 Steps (Variable)
	Mold Protection Function	
	Mold Open Close Servo Motor With Brake	
	Ejector Servo Motor With Brake	
	Electric-driven Mold Thickness Adjusting Device	
	Auto Clamp Force Setting	
	Clamp Force Display	
	Clamp Force Feed Back Control	
	Ejector Plate Return Confirmation Circuit	
	Toggle Type Injection Compression Function	A-mode B-mode Compression: 1 to 6 Steps (Variable)
	Parallel Motion	Screw Rotation During Mold Open/Close Eject During Mold Open Injection During Clamp Up
	Clamping Unit Safety Device (Electrical)	
	Robot Mounting Holes	
	Grease-free Toggle Bushing	
	Auto Grease Lubrication	

Item	
Controller	Multi-touch Panel 15" TFT Color LCD Controller
	Multi-language Select (English, Chinese, Japanese)
	300 Mold Conditions Storage (Internal Memory) (Note 3)
	Soft Start Molding
	Self Diagnostics Function
	I/O Customize Function
	Molding Operation Assist Function
	Help Function
	Pop-up Display
	Manual Browsing Function
	Start-up Safety Notice
	Molding Condition MEMO
	Screen Capture Files can be stored to USB memory device (Note 4)
	Overall Setting Screen
	Pre-heat Timer
Monitor	Product Takeout Robot Circuit
	Attended/Unattended Operation Select
	Actual Value Display
	Injection/Metering Waveform Monitor
	Injection/Metering Waveform Storage
	Oscilloscope Waveform Monitor
	Energy Consumption and Regeneration Monitor
	Barrel Temperature Monitor
	Injection Pressure Monitor (IPM)
	Statistical Graph
	Production Monitor
	Cumulative Operating Hour Display
	Cycle Monitor
	Molding Condition Upper/Lower Limit Monitor (Note 5)
	Inspection and Maintenance Guide (Note 6)
Heater System Alarm	
Injection Pressure Overshoot Alarm	
Servo Fault Alarm	
Grease Lubrication Alarm	
Fault Alarm Buzzer	
Alarm History	
Set Value History	
Others	Safety Compliance to ISO20430, ISO60204-1
	Cooling Water Closed Circuit for Feed Throat
	Accessories (Maintenance Tools and Ejector Rods, etc.)

- (Note)
- Nozzle of 2300H is one piece type nozzle.
 - Screw of injection units 300H, 460H, 890H and 1400H, GP21 screw is equipped as standard.
• Screw of injection unit 2300H, M3-CL screw is equipped as standard.
 - USB memory device as external memory is capable of storing of molding conditions.
 - Screen Capture can be saved in PNG format, and measuring data can be saved in CSV format.
 - Maximum of 16 items and alarms can be selected out of the following monitor items.
① Cycle time ② Injection time ③ Metering time ④ Max Injection pressure ⑤ Cushion position
⑥ Holding pressure end position ⑦ Holding pressure transfer pressure ⑧ Screw back pressure
⑨ Metering end position ⑩ Injection start position ⑪ Holding pressure transfer position
⑫ Metering torque ⑬ Holding pressure transfer speed ⑭ Mold close time ⑮ Mold open time
⑯ Clamping force ⑰ Shift stroke (HAVC) ⑱ End speed (HAVC)
 - Maintenance monitor based on molding condition

Options List

Item	
Injection unit	Long Nozzle
	Shut-off Nozzles (Pneumatic Type and Hydraulic Type) (Note 1)
	KC Nozzle
	M7 Screw (High Plasticization Type)
	HP Screw (High Dispersion Type)
	LSP-2 screw (Abrasion-resistant type)
	Screws and Barrels for Optical Application
	Screws and Barrels for Super Engineered Plastics Application
	Special Screw (Note 2)
	Barrel Insulation Cover
	Barrel Blower Cooling Unit
	Hopper
	Hopper Slide Device (Operation Side)
	High-speed Injection
	Extended Holding Time Spec. (Note 3)
Clamping unit	Daylight Extension
	Mold Platen Heat Insulation Bord (5 or 10mm) (Note 4)
	Locating Rings
	Air Jet
	Core Pull Devices (Pneumatic Type and Hydraulic Type)
	Valve Gate Device (Pneumatic Type and Hydraulic Type)
	Coupler joint (Hydraulic, Pneumatic)
	Hydraulic Power Pack (40L or 60L) Internal Unit
	Ejector Gate Cutting Circuit
	Unscrewing Motor Circuit
	Product Drop Detector (Photoelectric)
	Chute
	Rejecting Product Detecting Chute
	T-groove Platen
	Mold Setup Device
Mold Clamper Device (Pneumatic Type, Hydraulic Type, Magnet Type) (Note 4)	
Mold Clamper	
Clamping Unit Safety Device (Mechanical)	

Item	
Electrical instrumentation and control	Multi-language Select (1 Language Additional)
	J-WiSe® solution (Note 5)
	Mold temperature display (with Mold Temperature Upper/Lower Limit Alarm)
	Mold Temperature Control device (with Mold Temperature Upper/Lower Limit Alarm)
	Hot Ranner Control Circuit
Other	Cooling Water Manifolds on Bed, Max. 60C-deg.
	Cooling Water Failure Warning
	Leveling Pad for Installation
	Machine Anchoring Device
	Signal Tower (1 Color, 3 Colors)
	Export Specification (Note 6)
	Designated Color (Bed & Covers only) (Note 7)

- (Note)
- Pneumatic shut-off nozzle and hydraulic shut-off nozzle can be mounted, Additional hydraulic unit is required for hydraulic type.
 - Contact sales to know the application.
 - The motor is prevented from being overloaded in a long holding time and high holding pressure molding condition.
 - Extension nozzle is required. Ask sales to confirm the nozzle length to meet requirement.
Note that the usable mold thickness range will change.
 - Please contact us for detailed specifications.
 - Ask sales to confirm the details depending upon the final destination.
 - Color sample or Muncell code is required.

Utilities

■ Total Power Capacity

Machine Model	Total Power Capacity (kVA)	
	Standard Injection	High Speed Injection
J220ADS	300H	20.0
	460H	27.0
	890H	34.0
J280ADS	460H	27.0
	890H	34.0
J350ADS	460H	27.0
	890H	35.0
	1400H	46.0
J450ADS	890H	36.0
	1400H	48.0
	2300H	56.0
		Not Applicable

- Note: 1. Total power capacity does not include external outlets.
2. We recommend that the rated interrupting current of the main power supply breaker is more than 25 kA at AC400V/460V.

■ Cooling Water Capacity for Barrel Temperature Control

Machine Model	Cooling Water Capacity for Barrel Temperature Control (ft ³ /h)
300H	14.12 (0.4m ³ /h)
460H	
890H	
1400H	21.20 (0.6m ³ /h)
2300H	42.38 (1.2m ³ /h)

Note: The above figures do not include the required quantity of water for the mold temperature controller.