

JT40RADS

55V

JSW

# JTADS SERIES

All Electric Servo Drive Vertical Type Injection Molding Machine

JT20RADS

JT40RADS

JT70RADS

JT100RADS

JT150RADS

JT220RADS

Made in HIROSHIMA

JSW



JQA-QMA13993  
JQA-EM6416

Combining our experience with new technologies to deliver the best to our customers.

*New Compact Design Packed with Features*  
*This is our next generation all electric servo driven vertical*

## 4**S**olutions

*for diverse injection  
molding workplaces*

### **S**mall & Strong

**Compact design, yet providing maximum performance**

New compact design that combines ease of use and a high level of functionality, including expansion of mold mounting area and optimization of table height.

### **S**table

**Highly accuracy injection - recovery control**

Stable operation and product accuracy improvement with screw and barrel variations and high accuracy volume control functions.

### **S**atisfaction

**Controller to satisfy various needs**

SYSCOM5000<sub>z</sub> controller realizes user friendly operation with a full range of functions such as operation process indication and individual injection process set-up for 2 molds, which is suitable for rotary type machine.

### **S**mart

**IoT Solutions J-WiSe™**

J-WiSe turns our customers' factories into smart factories.

*injection molding machine.*

# JTADS SERIES

- JT20RADS
- JT40RADS
- JT70RADS
- JT100RADS
- JT150RADS
- JT220RADS

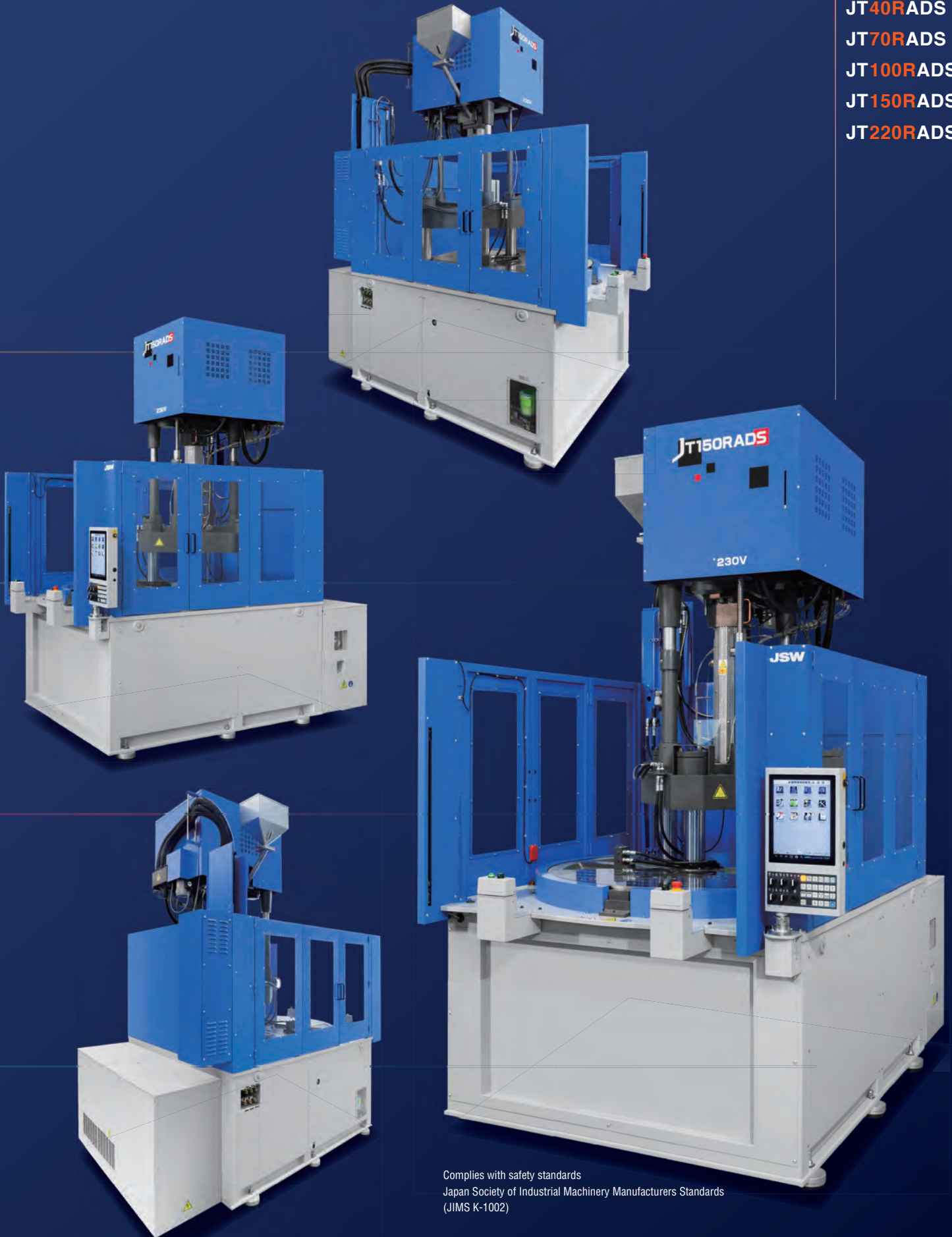

Complies with safety standards  
Japan Society of Industrial Machinery Manufacturers Standards  
(JIMS K-1002)

# S Significantly larger mold mounting area and more flexibility

## Small & Strong

### Significantly improved insert and setup efficiency Optimized table height

A newly developed toggle mechanism brings the lowest table height machine in the industry.  
Significantly improved flexibility during production and setup.

Item	Series	Model	JT20R	JT40R	JT70R	JT100R	JT150R	JT220R
			Table height (mm)	AD	884	889	995	1077
ADS	795	800		971	993	1173	1387	

Improves workability

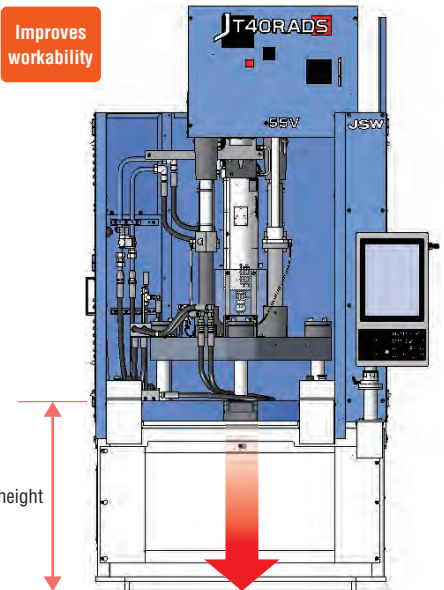

### More secure and stable clamping device

#### Optimized clamping mechanism

High speed and high accuracy mold opening and closing through an optimized toggle-type clamping device design.

#### Advantages of the JSW toggle-type clamping mechanism

Faster mold speeds compared to direct clamp machine

Reduced cycle time

Higher repeatability than hydraulic machines

Greater accuracy in molded parts

#### Triple motor brake

Standard mounting of brake on motor for table rotation/EJ/clamping

Protects molds even in unexpected situation such as blackouts

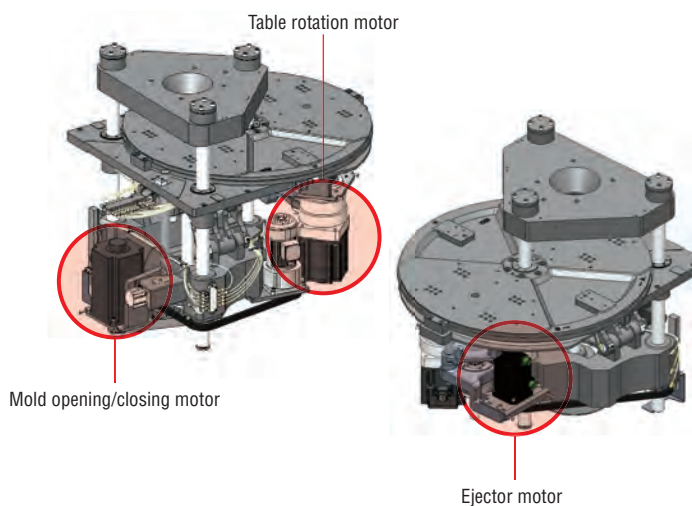

#### New mold protection function (mold closing torque monitoring)

Further improvements in mold protection performance via a new control mechanism in addition to standard mold protection.

- Multi-stage settings of mold protection
- High degree of safety through simple settings
- Tracks mold temperature changes

#### ■ Mold closing torque monitoring image

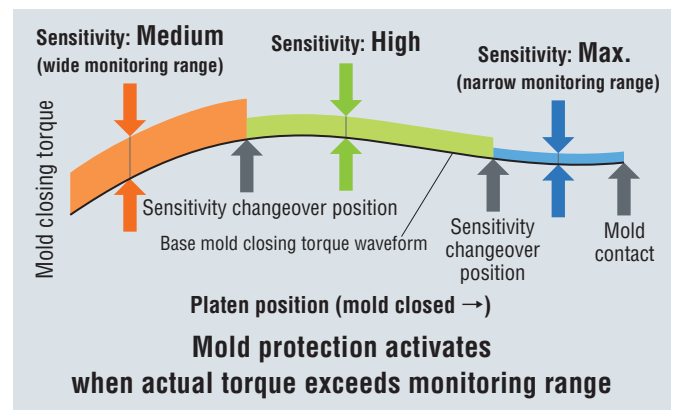

Only two values need to be set

- Mold protection monitoring sensitivity
- Changeover position ▶ Easy to set !

## Expansion of mold mounting area

Multiple use

The allowable mold size has increased due to daylight extension and a larger rotary table. \* Excludes some models  
Wide specification platens for 100 tons and 150 tons are now part of the product lineup.

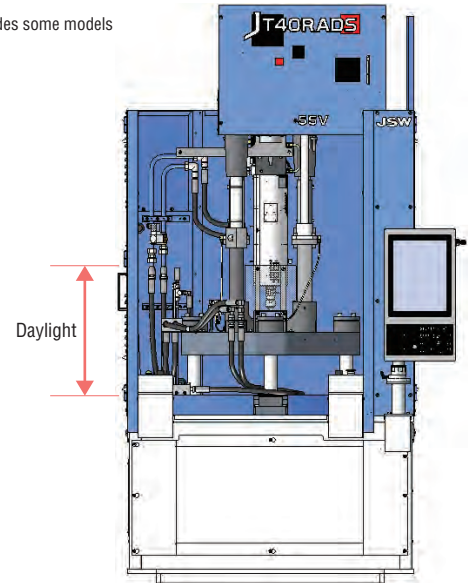
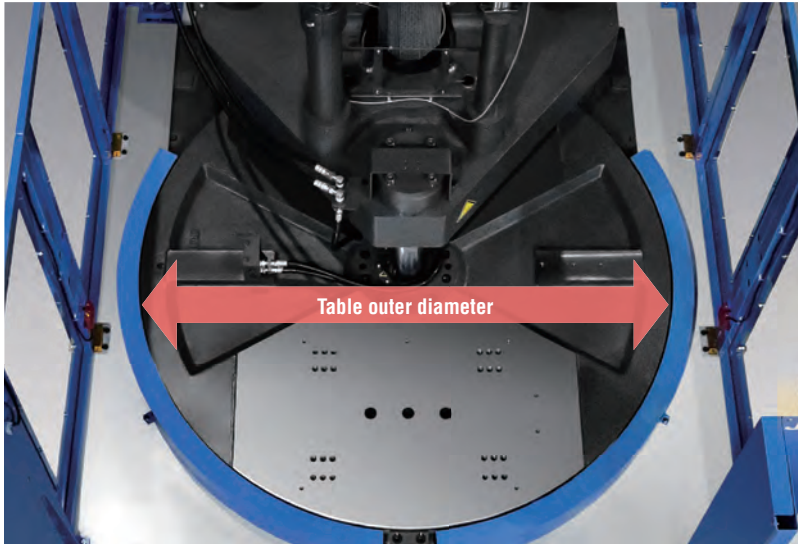

Item	Series	Model	JT20R	JT40R	JT70R	JT100R	JT150R	JT220R
		Daylight (mm)	AD	430	470	550	600	650
		ADS	430	490	550	640	710	850

Item	Series	Model	JT20R	JT40R	JT70R	JT100R	JT100R-Wide★	JT150R	JT150R-Wide★	JT220R
		Table outer diameter (mm)	AD	912	1032	1160	1310	—	1490	—
		ADS	912	1032	1200	1310	1400	1490	1600	1760
Mounted mold dimensions Square (mm)	AD	AD	308	365	406	457	—	510	—	661
		ADS	308	365	430	479	512	524	566	661
Mold allowable mass (kg) * ADS only	Upper	Upper	80	150	200	300	300	400	400	500
		Lower	150×2	225×2	300×2	400×2	400×2	500×2	500×2	690×2

★ Wide platen specifications are optional.

## Reduced factory floor space requirements

— Machine width reduction —

Space saving

The bed has been reduced from the conventional model.  
Easy to layout robot and incorporate the machine on the assembly line by reduction of machine width.

Item	Series	Model	JT20R	JT40R	JT70R	JT100R	JT150R	JT220R
		Machine width (mm)	AD	1385	1385	1405	1710	1900
		ADS	1220	1220	1400	1600	1800	1960

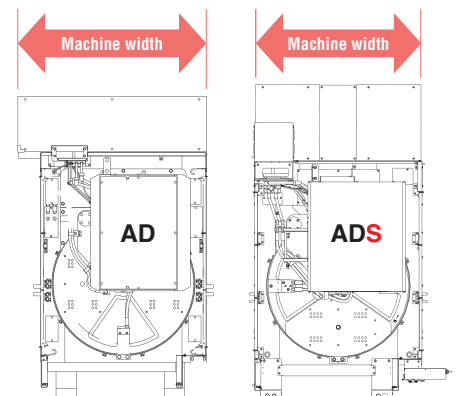

## JSW's original high accuracy volume control

Improved stability

Improves mold product quality by JSW's unique measurement stability control.

### Reverse seal control

The screw is reversed after recovery ends to help the back-flow prevention ring close and to inhibit drooling.

### IWCS (Injection Weight and Cushion Stability)

The density of molten resin is controlled after recovery.

### HAVC (High Accuracy Volume Control)

The reverse seal and injection stroke after re-pressurization are constantly controlled.

■ Before reversal

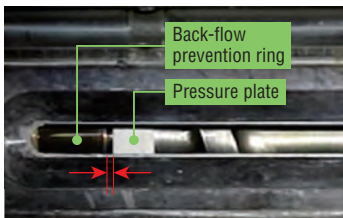

■ After reversal

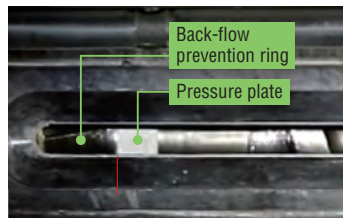

Promotes closure of the back-flow prevention ring after reversal

Variations in product weight

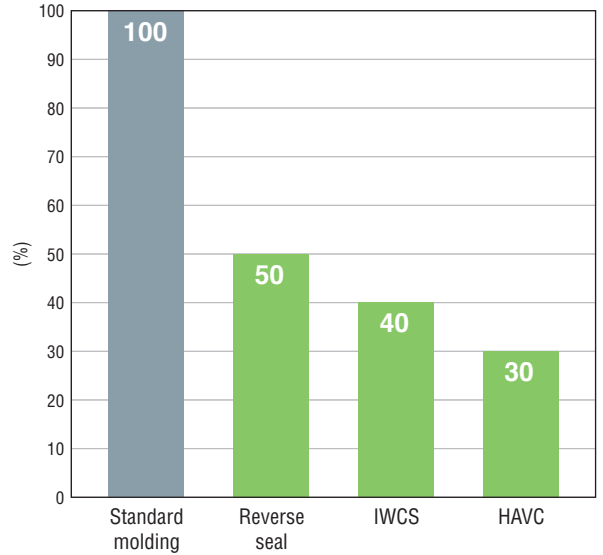

## Various injection unit combinations

Optimization

A new injection unit combination (520 V) has been added to be able to cope with injection volumes that could not be handled by conventional models. This makes it possible to mold large products.

Clamping unit	Injection unit	Screw diameter (mm)	Theoretical injection capacity (cm <sup>3</sup> )
JT20RADS	20 V	18	17
		20	20
		22	25
JT40RADS	55 V	25	44
		28	55
		32	72
		35	88
JT70RADS	110 V	40	138
		45	182
		50	231
JT100RADS	230 V	53	285
		58	307
		63	408
JT150RADS	410 V	68	489
		75	621
		80	720
JT220RADS	520 V New	80	864
		90	1080
		100	1440

## Reduced heater power consumption

Improved energy saving

A heater insulation cover is installed as standard to reduce power consumption.

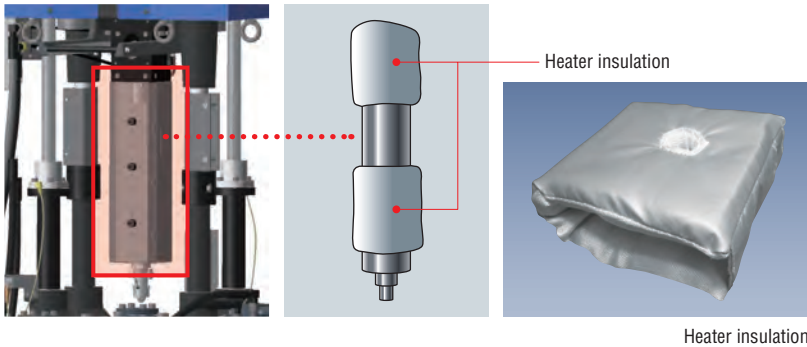

Power consumption during molding (barrel heater)

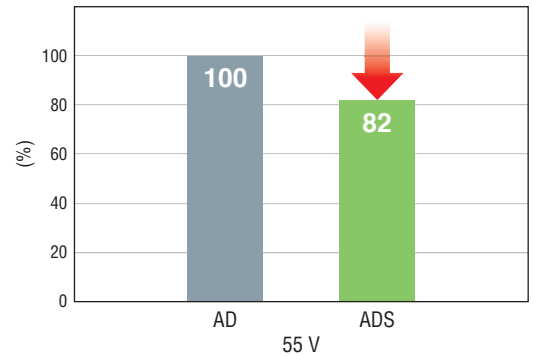

## Screw barrel combinations Expansion of PPS/PA dedicated screw barrel (optional)

Increased durability

JSW has developed PPS/PA dedicated screw barrel often used in vertical molding machines.

Dedicated screw barrel consist of N3000G barrel, dedicated screw and SG screw head set. \* Works from 55 V to 230 V

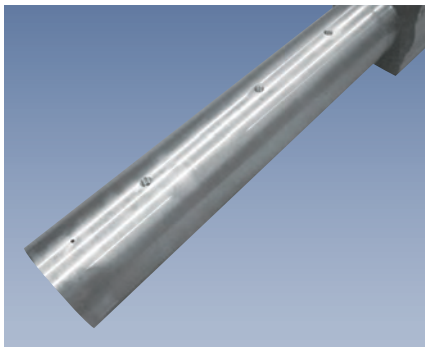

N3000G barrel

### Abrasion resistance/corrosion resistance comparison data

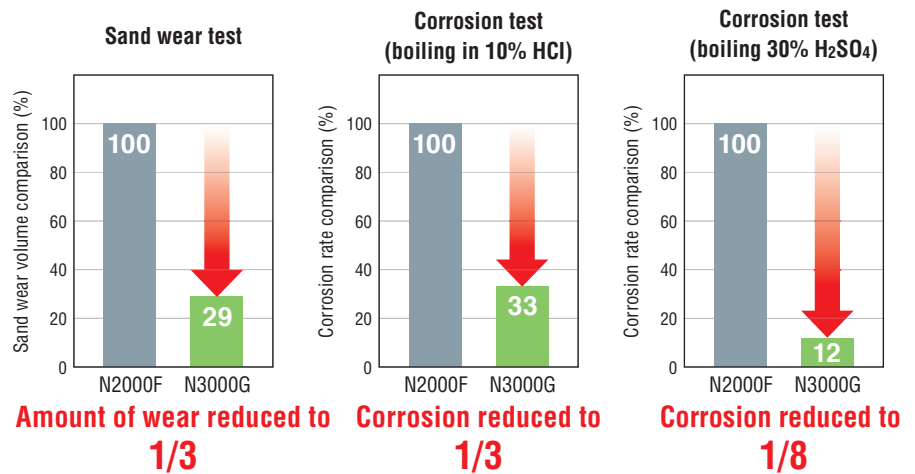

\* These data were obtained using test equipment and do not guarantee the performance of the product.



SG screw head

### Resin pressure difference comparison data front and back of back-flow prevention ring during PPS resin metering

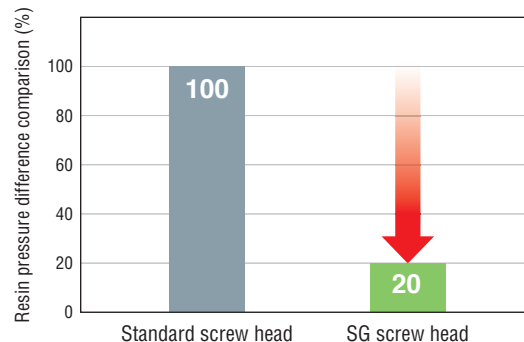

**Longer life achieved by reducing the contact force of the back-flow prevention ring to the screw head**

# Satisfaction

The new controller SYSCOM5000i to satisfy various needs

## Easy operation and increased functionality

Main characteristics of SYSCOM5000i:

- Casual multi-touch operation
- Simple lever operation
- User-manual display function
- Improved visibility and better ergonomics through a larger settings screen
- Large 15" display featuring energy-saving LED technology
- 300 molding conditions can be saved and 10,000 measurement values can be accessed

\* Internal memory: 300, expandable with USB memory

Improved functionality

Improved operability

## User-friendly screen configuration

### Operation process display

The operation of each molding process can be visualized for greater comprehension.

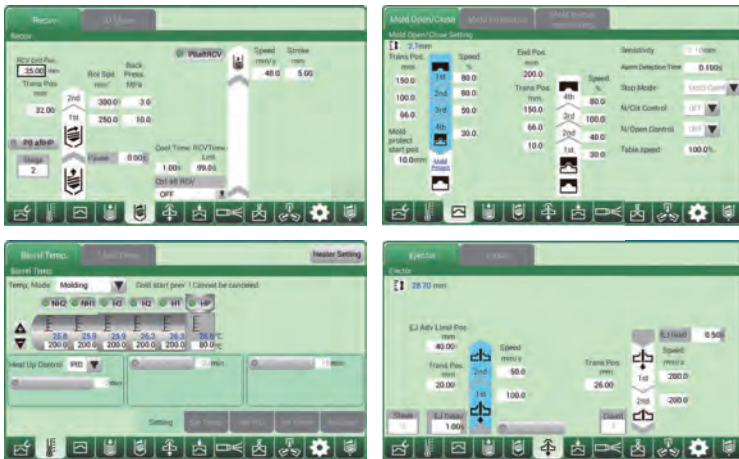

### Overall setting screen

Molding conditions can be set without having to navigate through numerous pages.

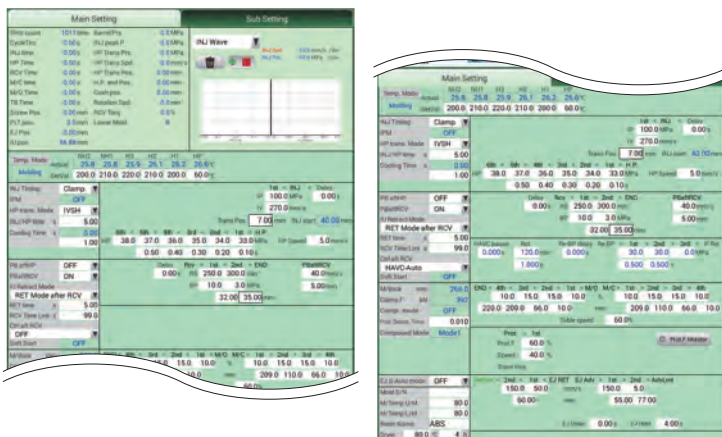

### Cycle monitor

Current process condition of the injection molding machine is easily checked visually.

Machine	Mon. val	Cycle	Power	Wave Graph	Actual	History
Current / Last Time(a)						
TB Mov.	1.81	1.81			1.50 / 1.50	
M/C	3.39	3.39				
INJ	0.26	0.26				
H.P.	2.74	2.74				
Cool	8.72	8.72				
Rcv	2.88	2.88				
PB afterRCV	0.67	0.67				
M/G	1.30	1.30				
Ejection	0.73	1.74				
Cycle	22.58	22.18				

Print on cycle end if screen is changed with Print on cycle end turned to ON, Print on cycle end is canceled.

## Further energy savings in electric machine

Improved energy saving

Helps reduce power consumption by visualizing power consumption.

### Power consumption display function

Power consumption can be displayed on the controller.

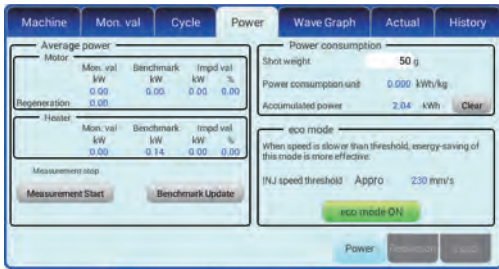

### Power consumption reduction support

Proposes molding conditions that lead to reduced power consumption.

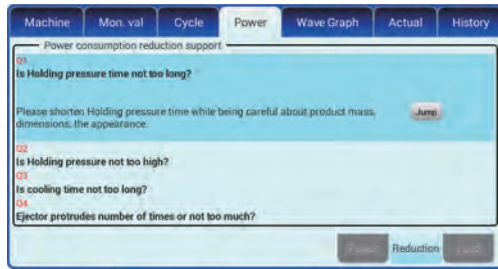

## Reduces workload, promoting efficiency

Improves workability

Improves the working efficiency of molding workers through various functions.

### Molding condition memo

In addition to molding conditions, it is possible to save notes on molding, settings of auxiliary equipment, images of molded products, etc.

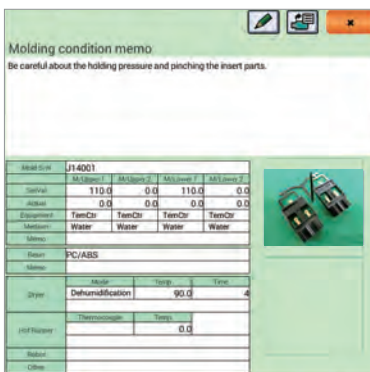

### Screen shots/ handwritten memo

Add and edit handwritten information on the cut screen shot.



## Rotary machine-specific 2 condition injection standard equipment

Standard specifications can be used even with a different lower mold shape.

Improved functionality



Screen A

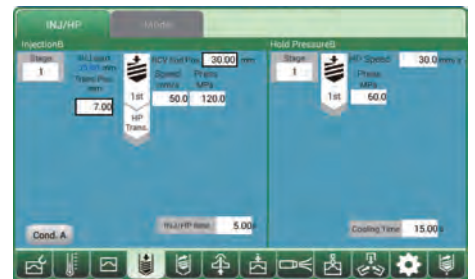

Screen B

### User-manual display function

The user instruction manual can be referenced from the molding machine controller.

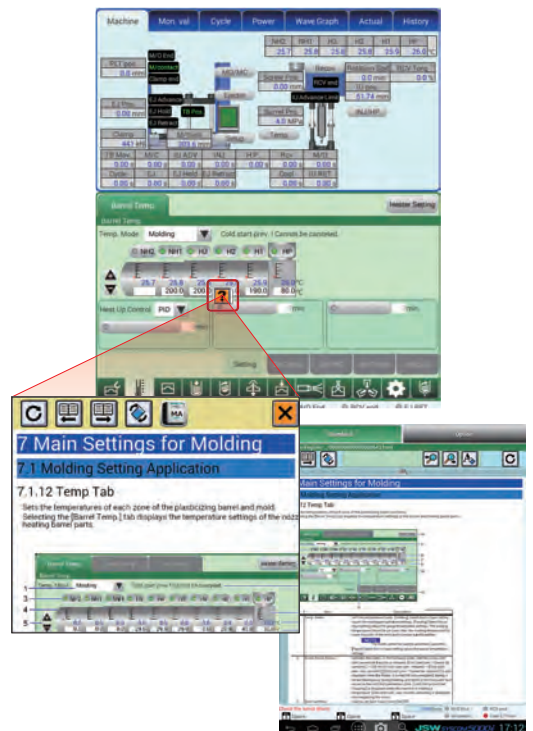

## Productivity improvement by creating a smart factory

Improved functionality

Improved operability



## 1 Production management Supports visualization of manufacturing sites

Centralized control system NET100 \* Optional

- Record the operation status of each molding machine and measured value data and display it remotely.
- Can be linked with the user's production management system.

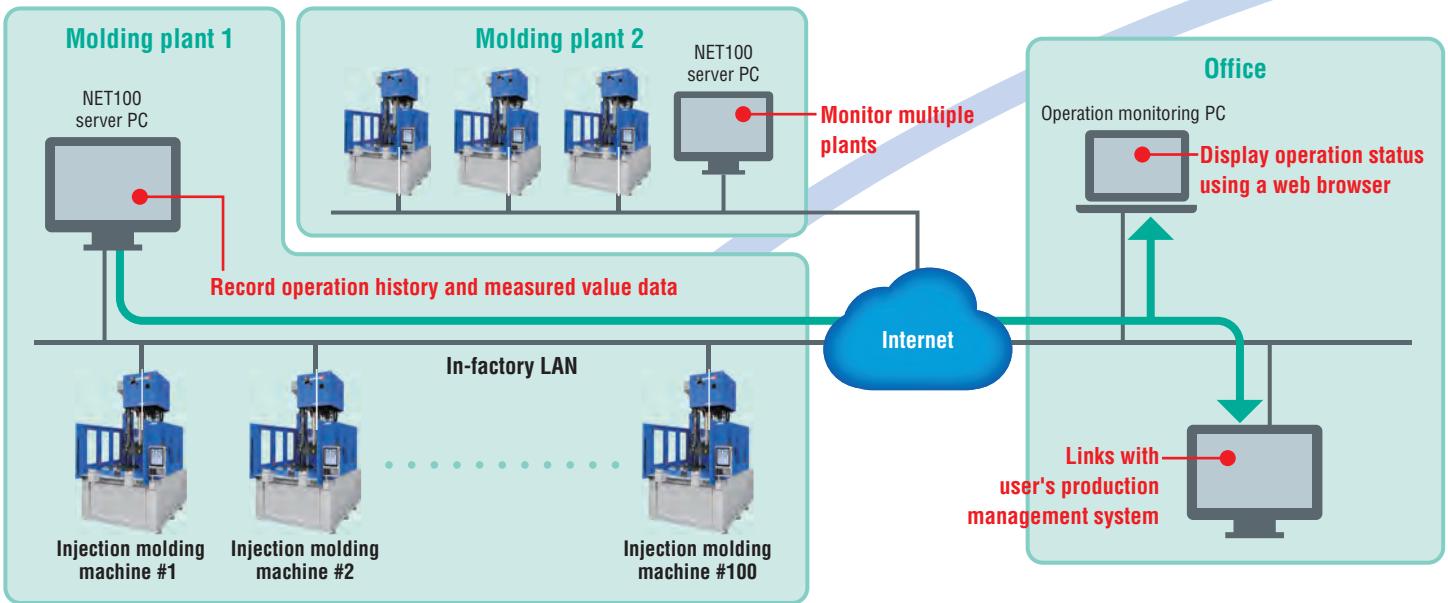

### Monitoring of operation status

No.	Name	Molding Condition	Status	Shot Count	Cycle Time (s)	Shot Date	Operation Log	More	Edit
1	SYSCOM0001	TEST1	Production	280	13.55	Shot Date	Operation Log	More	Edit
2	SYSCOM0002	TEST2	Production	86458	10.23	Shot Date	Operation Log	More	Edit

### Display and operation of controller screen

No.	Name	Molding Condition	Status	Shot Count	Cycle Time (s)	Shot Date	Operation Log	More	Edit
1	SYSCOM0001	TEST1	Production	280	13.55	Shot Date	Operation Log	More	Edit
2	SYSCOM0002	TEST2	Production	86458	10.23	Shot Date	Operation Log	More	Edit

### Analysis of measured values

SN	File	Time	Quality	Cycle Time (s)	Time Remaining	T-Product (sec)	R-SP
49493	2016-06-01	13:00:04	0	6.84	0.55	2.58	52.00
49494	2016-06-01	13:00:11	0	6.84	0.55	2.59	52.00
49495	2016-06-01	13:00:18	0	6.84	0.55	2.59	52.00
49496	2016-06-01	13:00:24	0	6.85	0.55	2.59	52.00

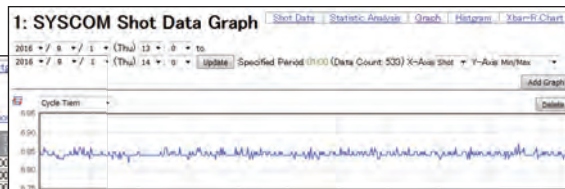

### Display and management of molding conditions

No.	Temp	Test/PS/PE	Unit	Time	Temperature
1	Temp Test/PS/PE	SI		20100804	16:21:08
2	Temp Test/PS/PE	Misc		20100827	10:46:56
3	Gate Seal/SD-SE	SI		20100804	16:25:14
4	Weight var/PS	SI		20100407	20:58:36
5	0.3tLSP Special			20091206	19:34:52
6	J8W mold 0.4 pr 0.6			20090127	16:11:00
7	Spiral Flow/PS			20100407	20:57:14
8	Spiral Flow/PS			20100407	20:57:52
9	Deco-Block/PS/PA/OK			20100407	21:04:42

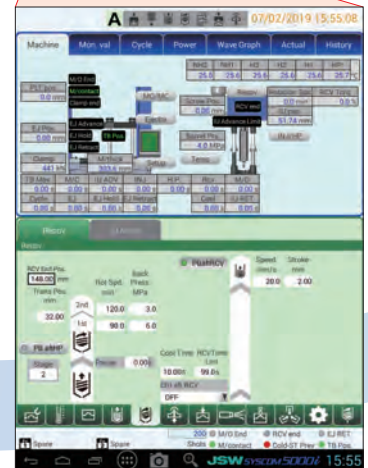

## Maintenance Reduces machine downtime

### Battery replacement indication

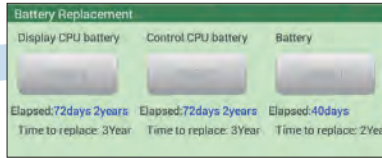

**Ball screw predictive maintenance function**  
Gives ball screw inspection advice in consideration of molding conditions.

### Maintenance memo

Molding machine maintenance history can be saved in the controller.

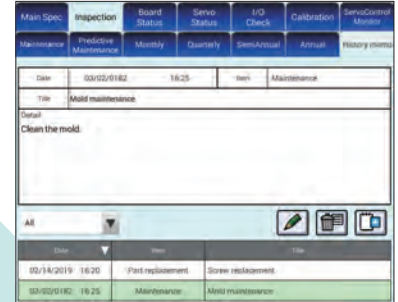

J-Wise : JSW Worldwide IoT Solutions of Enhancement



## Molding support Support for setting conditions via the SYSCOM 5000 controller

Mold start-up support function that is easy to use for less experienced workers, covering mold setup, initial mold condition setting, and measures against defects.

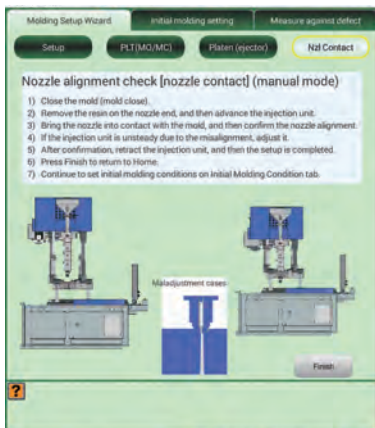

### Molding setup wizard

Support for work from mold setup to nozzle touch.



### Initial molding setting

Initial mold conditions are proposed upon inputting molded product information.



### Measure inferior hint

Provides tips to avoid various molding defects.



## Production automation system Connected JSW injection molding machine

A production system can be combined by integration with auxiliary equipment.



### IO customize (optional)

The user can create simple sequences.



Integrated with auxiliary equipment

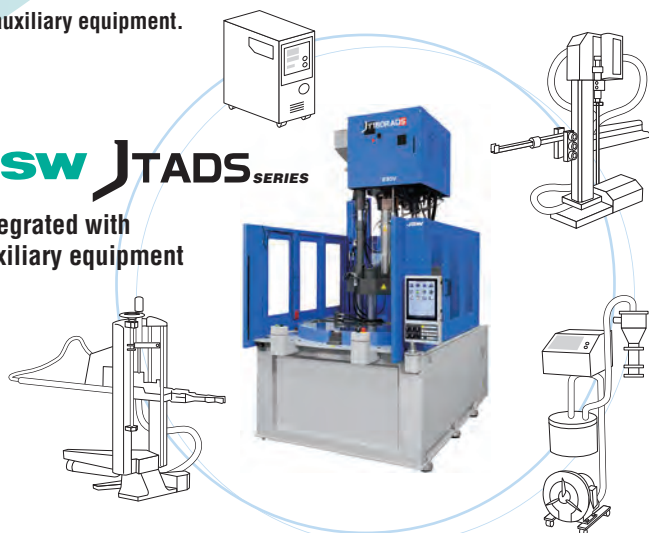

# Standard & optional equipment

User requests can be satisfied through full of standard equipment and various optional equipment that makes further usability.

\* The following items represent a selection of available options.

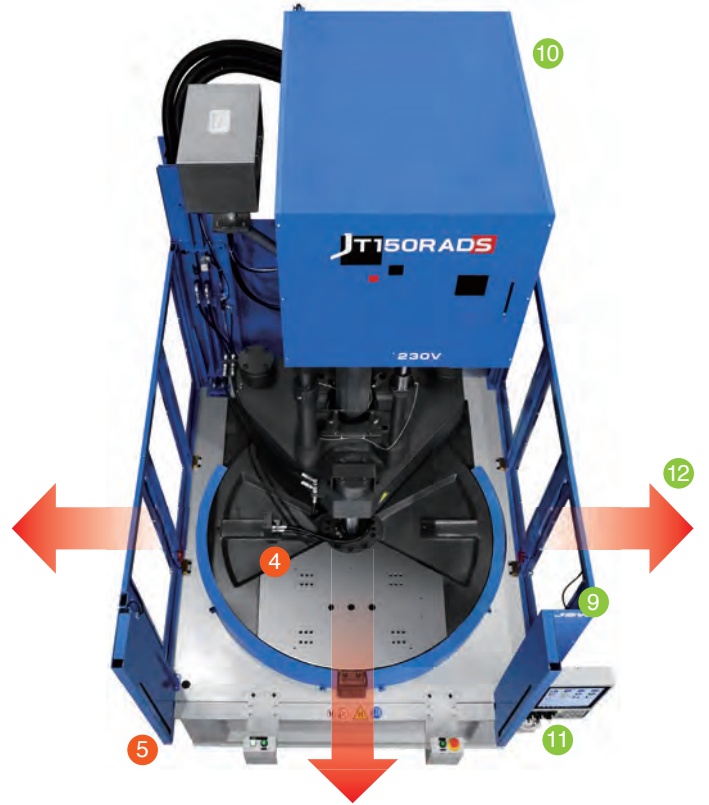

## Standard equipment

1 Water supply and drainage ports	2 Air pressure gauge	5 Light curtain
3 Automatic greasing device (cartridge type)	4 Table top piping	

## Optional equipment

6 200V outlets	11 Injection compression function	
7 Hopper	8 Robot connection circuit	9 Rotating warning light (3 colors)
10 High-speed injection specifications (HS) * 20V, 55V or 110V can be selected with the same machine dimensions.		12 90 deg., 270 deg. mold setup

# Smooth integration with automation

Customizable according to the customer's request.

\* Please contact us for special specifications.

## Horizontal injection specification machine

An example system that automatically performs everything from insert to product inspection.

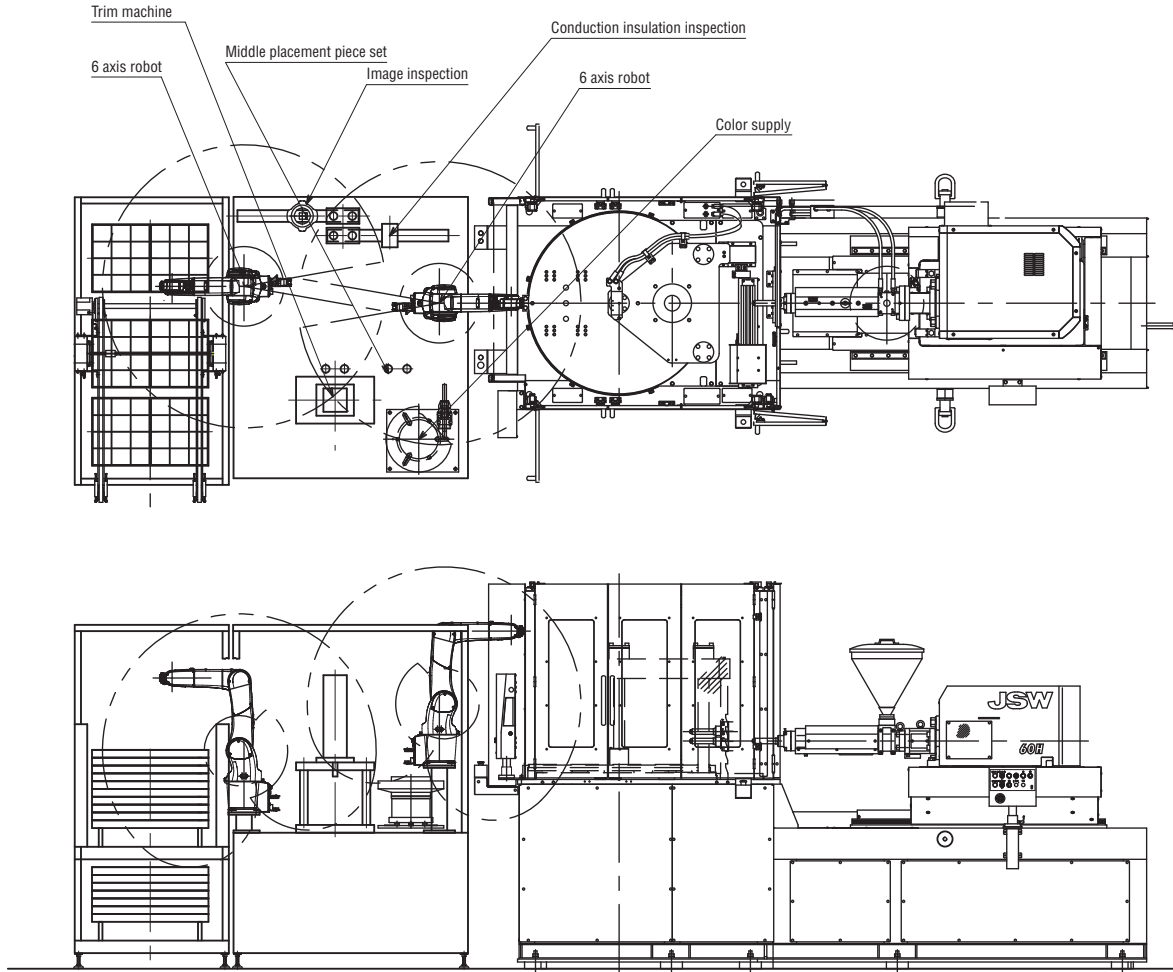

## Horizontal injection (two colors), one-direction table rotation specification machine

Two-color molding can be performed, and the one-direction rotation four-station method gives added value and improves productivity.

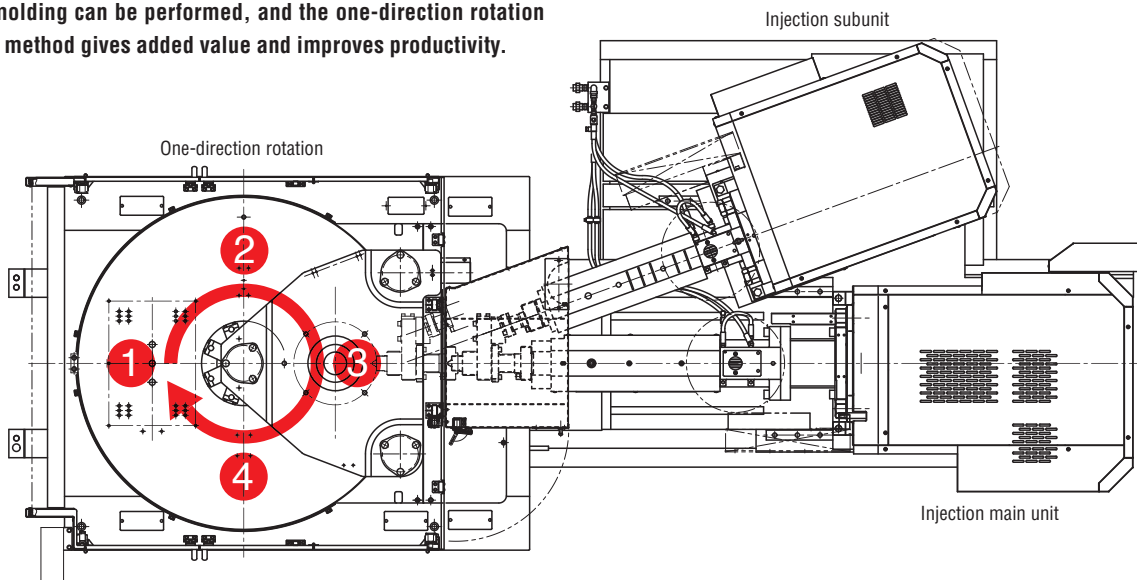

# Standard equipment

Item		Item			
Injection unit	KC nozzle (tip type)		Controller	Multi-touch panel 15" TFT color LCD controller	
	N2000F barrel			Multi-language select (English, Chinese, Japanese)	
	LSP-2 Screw (abrasion resistant type)			Molding condition storage (internal memory: 300 molds)*1	
	HT screw head			Lower two-die molding condition auto switching	
	Screw and barrel attachment/detachment device			Soft Start Molding	
	Screw cold start prevention			Self-diagnosis function	
	Molding/Purging/Pause temperature select			Molding operation assist function	
	Automatic purging circuit			Help function	
	Nozzle retract select			Pop-up function	
	Injection/metering programmed control	Injection/holding pressure: 1 to 6 steps (variable)		Manual browsing function	
		Metering/back pressure: 1 to 3 steps (variable)		Start-up safety notice	
	Holding control selection			Molding condition memo	
	Pull-back select			Screen capture files can be stored to USB memory device*2	
	Holding pressure control select			USB printer port*3	
	High accuracy barrel and nozzle temperature control			Overall setting screen	
	Synchronous temperature rise control			Pre-heat timer	
	Hopper flange temperature control			Attended/unattended operation select	
	Soft-pack servo control			Monitor	Actual value display
	HAVC (high accuracy volume control)				Injection/metering waveform monitor
	IWCS (injection weight and cushion stability control) control				Injection/metering waveform storage
Reverse seal control		Oscilloscope waveform monitor			
Automatic greasing		Energy consumption and regeneration monitor			
Barrel insulation cover		Barrel temperature monitor			
Clamping unit	Mold open/close and ejection programmed control	Mold open/close: 4 steps (fixed)	Injection pressure monitor (IPM)		
		Ejection: 1 to 3 steps (variable)	Statistical graph		
	Table rotation programmed control		Production monitor		
	Mold protection function		Cumulative operating hour display		
	Electric-driven mold thickness adjusting device		Cycle monitor		
	Auto clamping force setting		Molding condition upper/lower limit monitor*4		
	Parallel Motion	Screw rotation during mold open/close			Inspection and maintenance guide*5
		Eject during mold open			Heater system alarm
		Injection during clamp up			Injection pressure overshoot alarm
	Clamping safety device (mechanical and electrical)*1		Servo fault alarm		
	Photoelectric safety device		Grease lubrication alarm		
	Robot mounting holes		Fault alarm buzzer		
Grease-free toggle bushing		Alarm history			
Automatic greasing		User management function			
		Set value history			
		Others	Safety compliance to JIMS K-1002		
			Cooling water closed circuit		
		Accessories (maintenance tools and ejector rods, etc.)			

\*1 USB memory device as external memory is capable of storing of molding conditions.  
 \*2 Screen Capture can be saved in PNG format, and measuring data can be saved in CSV format.  
 \*3 The printer and printer cable are optional.  
 \*4 Alarms can be set for the following monitored items.  
 1. Mold identification 2. Cycle time 3. Injection start position 4. Injection time 5. Max injection pressure 6. Holding pressure transfer position  
 7. Holding pressure transfer speed 8. Holding pressure transfer pressure 9. Cushion position 10. Holding pressure end position 11. Metering time 12. Metering torque  
 13. Screw back pressure 14. Metering end position 15. Mold open time 16. Mold close time 17. Table rotation time 18. Shift stroke (HAVC) 19. End speed (HAVC)  
 \*5 Maintenance monitor based on molding condition.

# Options list

Item		Item			
Injection unit	Long nozzle	Electrical installation/Control	Multi-language select (1 language additional)*5		
	Shut-off nozzle (pneumatic type)		Centralized control system NET100		
	PPS/PA package		Mold temperature display (with mold temperature upper/lower limit alarm)		
	Special-purpose screw*1		Mold temperature control device (heater type)		
	Ultra-corrosion/abrasion resistant screw barrel*1		Spare outlet note*6		
	Hopper throat abrasion resistance sleeve		Spare outlet (100 V, 15 A x 2 ports) power supply customer*6		
	Screw and barrels for optical applications		Spare outlet (100 V, 15 A x 2 ports) with transformer*6		
	Abrasion resistant screw head type*1		Heater disconnection alarm		
	Hopper		Robot interface		
	Hopper attachment tube		I/O customize function		
	High speed injection specification		Others	Cooling water flow indicator	
	Extended holding pressure time specification			Cooling water failure warning	
	Residual resin alarm			Leveling pads for installation	
	Clamping unit			Daylight extension (+50 mm, +100 mm)	Rotary warning light (1 color, 3 colors)
				Mold platen heat insulation board (5 or 10 mm)*2	Export specifications*7
Locating ring		Designated color (bed & cover)*8			
Air jet					
Core pull devices (pneumatic type and hydraulic type)*3					
Unscrewing motor circuit					
Mold setup device (inside platen, outside platen)*4					
Mold clamber device (pneumatic type, hydraulic type, magnet type)*2, 3					
Easy mold clamber (easy clamp)					
Clamping force monitoring function					
Clamping force feedback control					
Upper die ejector (hydraulic type)*3					
Ejector 3 point ejection					
Ejector stroke extension					
Mold temperature control piping (for high temperatures)					
Mold one-direction access (270 deg. rotation)					
Ejector plate return confirmation circuit					
Toggle type injection compression function	Mode A				
	Mode B				
	Compression: 1 to 6 steps (variable)				
Wide model specification (100R, 150R)					

- \*1 Please contact us for specifications.
- \*2 When thermal insulation boards or magnet mold clammers are equipped, their thicknesses should be considered for calculating the nozzle insertion amount.
- \*3 A pump unit is separately required for the hydraulic type.
- \*4 When inside platen access device is equipped, the ejector stroke extension (optional) is required.
- \*5 English and Chinese are provided as standard languages.
- \*6 Please specify the power supply voltage and the number of outlets required for accessories.
- \*7 Regarding export specifications, discussion with JSW is required in some cases, depending upon the export destinations.
- \*8 Designate colors, referring to color samples or munsell codes.



**JSW THE JAPAN STEEL WORKS, LTD.**

<https://www.jsw.co.jp/en/>

Division Gate City Ohsaki-West Tower, 11-1, Osaki 1-chome, Shinagawa-ku, Tokyo 141-0032, Japan  
 Head Quarter: Phone: +81-3-5745-2081 URL [https://www.jsw.co.jp/en/products/injection\\_molding/](https://www.jsw.co.jp/en/products/injection_molding/)

**Japan Steel Works America, Inc.**

Head Office: 379 Thornall Street, 5th Floor, Edison, New Jersey 08837, U.S.A.  
 Phone: +1-212-490-2630  
 Los Angeles Office: 555 South Promenade Ave., Unit 104, Corona, California 92879, U.S.A.  
 Phone: +1-951-898-0934  
 Chicago Office: 540 Capital Drive, Suite 130, Lake Zurich, Illinois 60047, U.S.A.  
 Phone: +1-847-550-0704  
 Detroit Office: 24387 Halsted Road Unit B, Farmington Hills, Michigan 48335, U.S.A.  
 Phone: +1-248-536-0288

**The Japan Steel Works (Singapore) Pte. Ltd.**

17 Gul Lane 629413, Singapore  
 Phone: +65-6861-4511

**PT. JSW Plastics Machinery Indonesia**

Gajah Building Unit K, Jl.Dr.Saharjo No.111 Tebet, Jakarta Selatan 12810, Indonesia  
 Phone: +62-21-8370-2536

**JSW Plastics Machinery (Philippines) Inc.**

Unit 2205, 22nd Floor, Asian Star Building, Asean Drive, Filinvest Corporate City, Alabang, Muntinlupa City, 1781, Philippines  
 Phone: +63-2-478-2533

**JSW Plastics Machinery (M) SDN. BHD.**

D11-11-G, Pusat Perdagangan Dana 1, Jalan PJU 1A/46, 47301, Petaling Jaya, Selangor, Malaysia  
 Phone: +60-3-7842-6076

**The Japan Steel Works (Thailand) Co., Ltd.**

78/6 JST Building 4th Floor, Moo 7 King Kaew Road, Rachatewa, Bangplee, Samutprakarn 10540, Thailand  
 Phone: +66-2-738-5272

**JSW Plastics Machinery Vietnam Ltd.**

Hanoi Head Office: Room103, Techno-Center Thang Long Industrial Park, Kim Chung Commune, Dong Anh District, Hanoi, Vietnam  
 Phone: +84-24-3951-6383  
 Ho Chi Minh Office: Ground Floor, DC Tower, 111D Ly Chinh Thang, Ward 7, District 3, HCC, Vietnam  
 Phone: +84-28-3526-1295

**JSW Plastics Machinery (H.K.) Co., Ltd.**

Room 907, Corporation Park, 11 On Lai Street, Shatin N.T., Hong Kong  
 Phone: +852-2648-0720

**JSW Plastics Machinery (Shenzhen) Co., Ltd.**

1F, Yi Ben Electronic & Business Industrial Park, No.1063 Chaguang Road, Xili Town, Nanshan District, Shenzhen City, Guangdong Province, 518055, China  
 Phone: +86-755-8602-0930

**JSW Machinery Trading (Shanghai) Co., Ltd.**

301-304 Metro Plaza, No.555 Loushanguan Road, Changning District, Shanghai 200051, China  
 Phone: +86-21-5206-7031

**JSW Plastics Machinery (TAIWAN) Corp.**

Head Office: 1F, No.21, Dahu 1st Road, Gueishan Dist., Taoyuan City, 33373 Taiwan, R.O.C.  
 Phone: +886-3-396-2102

Tainan Office: 15F-7, No.689-78, Xiaodong Road, Yongkang Dist., Tainan City, 71052, Taiwan, R.O.C.  
 Phone: +886-6-311-4192

**Japan Steel Works India Private Limited**

611, Time Tower, MG Road, Sector 28, Gurgaon, Haryana, 122001, India  
 Phone: +91-124-469-4444

